

THE SOLAR-HYDROGEN HOME



RODRIGO PENA (NASSAU COMMUNITY COLLEGE)
Prof. HAZEM TAWFIK (SUNY FARMINGDALE)
**Prof. MAHAJAN DEVINDER (BROOKHAVEN NATIONAL
LABORATORY)**
CCI PROGRAM, SUMMER 2006



ABSTRACT

- As oil prices continue to escalate to levels that threaten our economy, alternative energy is starting to play an important role in our society. Hydrogen fuel cells and solar panels are alternatives that promise a non pollutant way of producing energy. A solar cell is a p-n junction, made out of silicon (semiconductor). A p-n junction is the product of two layers of the same semiconductor material that are doped with different materials to leave one free electron in a layer, and a deficit of one electron in the other layer. A photon will move this free electron from one layer to the other, inducing an electrical field at the interface of these two layers, and a current will flow when the circuit is closed. A solar energy arrangement (photovoltaic system) will be used to meet the load of an average household that requires approximately 10,000 kWhr of energy per year. The objective of the current work is to put together a cost effective model house scaled down 1:300 of the energy required for an average residential home to conduct system and energy analysis. The Photovoltaic (PV) size facing south required to meet the load of an average household is 9 kW with efficiency of 75 % that counts for inverter and wiring losses of the system. In this project, two solar panels measured at 15 watts each will simulate the 9 kW PV system. These two solar panels will be used to feed the total consumption of the model house. In New York, the average sun hours per day are 4.3 hours, during which the PV system will produce the total energy needed to run the house for the whole day. The excess portion of solar energy that is not used during the 4.3 hours will be used to electrolyze water and generate hydrogen and oxygen. The hydrogen is stored in tanks to be used after the sun set to produce energy on demand by hydrogen fuel cells. The current experimental work showed that for 9 kW – PV system, the hydrogen production is one fourth the total amount needed to cover the energy demand for the remaining hours of the day after sun set. This is attributed to the efficiencies of the fuel cell and Electrolyzer at the current state of technology.

OBJECTIVES

- ❑ To experimentally analyze and represent the energy demand and solar hydrogen fuel cell energy supply of a real average house in a 1:300 scale model.
- ❑ To save time and money on the design of future residential homes using this model
- ❑ Within this experiment we will include:
 - Calculations for the amount of energy that could be used to generate hydrogen by the use of PV systems.
 - Calculations to determine if the energy production from the fuel cells arrangement would meet the 100% energy requirements of a residential house after sun set
 - Calculations of the efficiencies of using Solar-Hydrogen systems in residential applications.



HYPOTESIS

- ❑ The sun has enough energy to cover all human needs, we just have to know how to store this energy.
- ❑ Hydrogen Fuel Cells have high efficiency levels, and could be used as the alternative for batteries and net metering in photovoltaic systems.

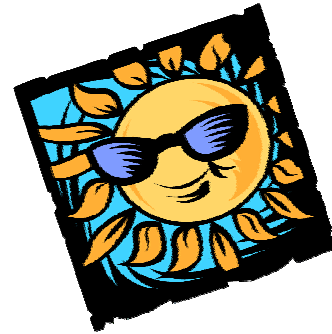

PROCESS OVERVIEW

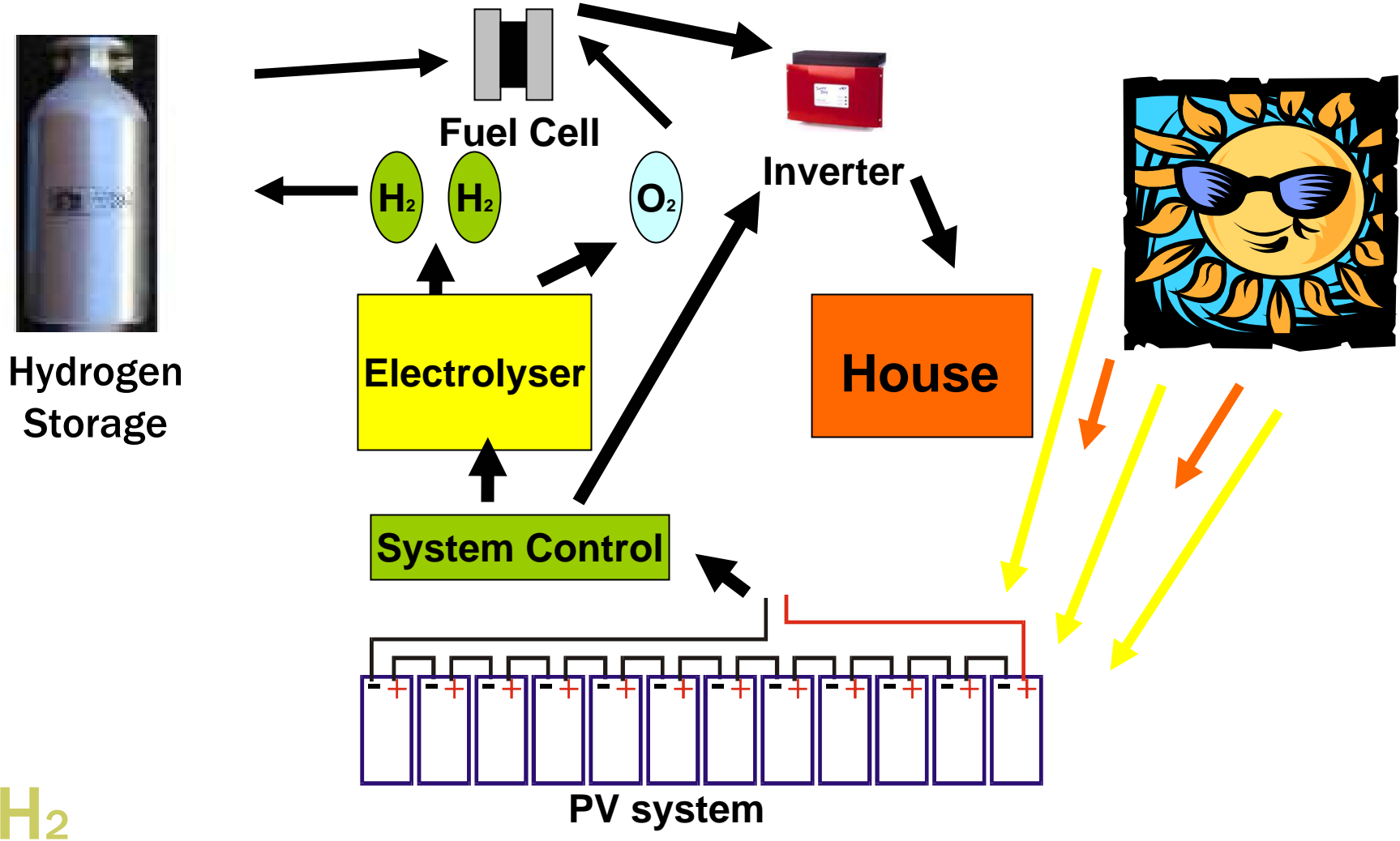

H_2

ENERGY CONSUMPTION RATE FOR THE REAL SCALE HOUSE

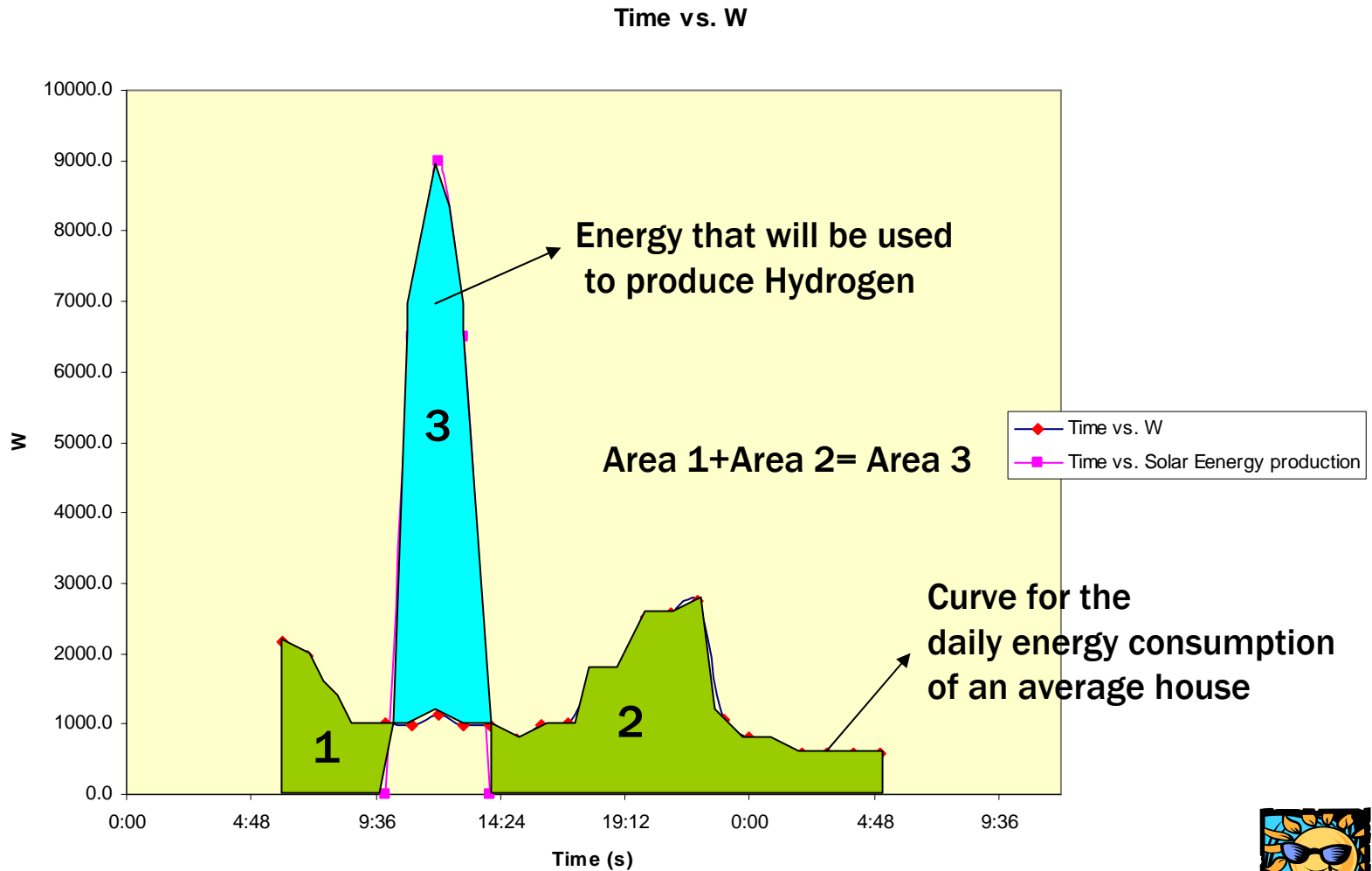

H₂



SOLAR PANELS OUTPUT

JUNE 21
Average

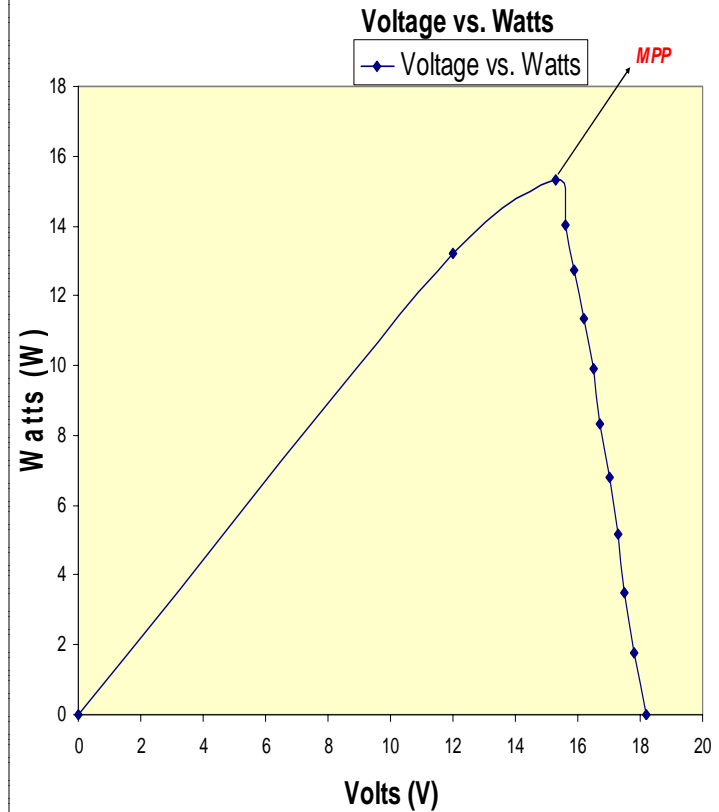
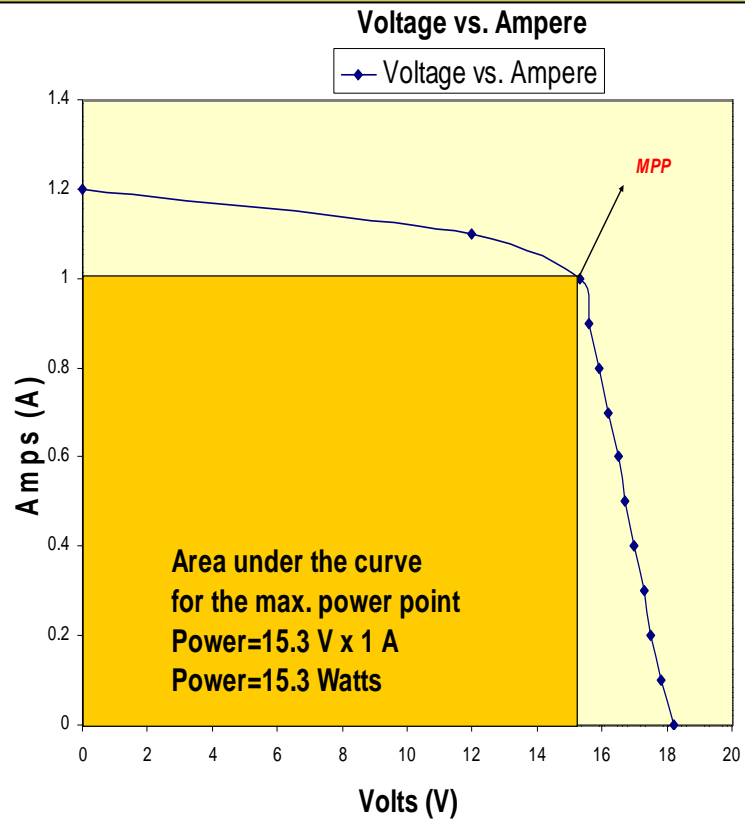

SOLAR PANELS EFFICIENCY

- (100 % efficiency) is defined as 1 KW of solar radiation that 1 sq meter of earth intercepts in 1 Hour
 - This is the base for calculating efficiency
- Our solar panels:
 - Area: 0.22 sm
 - Power output (avge): 15 watts
 - Therefore, Efficiency: 7 %



H₂



SCALE FACTOR

- ❑ Load of real scale house: 10,684.41 kWhr/year
- ❑ PV size required for Average house: 9.08 kW
- ❑ Power Scale factor : $9000 \text{ W} / (2 \times 15 \text{ W}) = 300$

- ❑ Dimension scale:
 - Floor Plan
 - Real house: 700 sft
 - Sample house: 7 sft
 - Scale factor: 100

 - Roof :
 - Real House: 1000 sft
 - Sample house: 10 sft
 - Scale factor: 100





CALCULATIONS

- Total power required for Real scale House is 22372 Watts

- Sample House
 - $22372 \text{ Watts} / 300 = 74.57 \text{ Watts}$

 - Energy consumption : 35.61 kWhr per year (sample house)

 - PV size required: 0.03 kW (sample house).

 - PV daily energy production: $0.03 \text{ kW} \times 4.3 \text{ hrs} \times 75 \% \text{ efficiency} = 96.75 \text{ Whr/day}$

 - Amount of energy consumed by model in 4.3 hrs: 17.3 Whr

 - The amount of energy that will be used to produce hydrogen will be $96.7 \text{ Whr} - 17.3 \text{ Whr} = 79.42 \text{ Whr per day}$



H₂

CIRCUIT

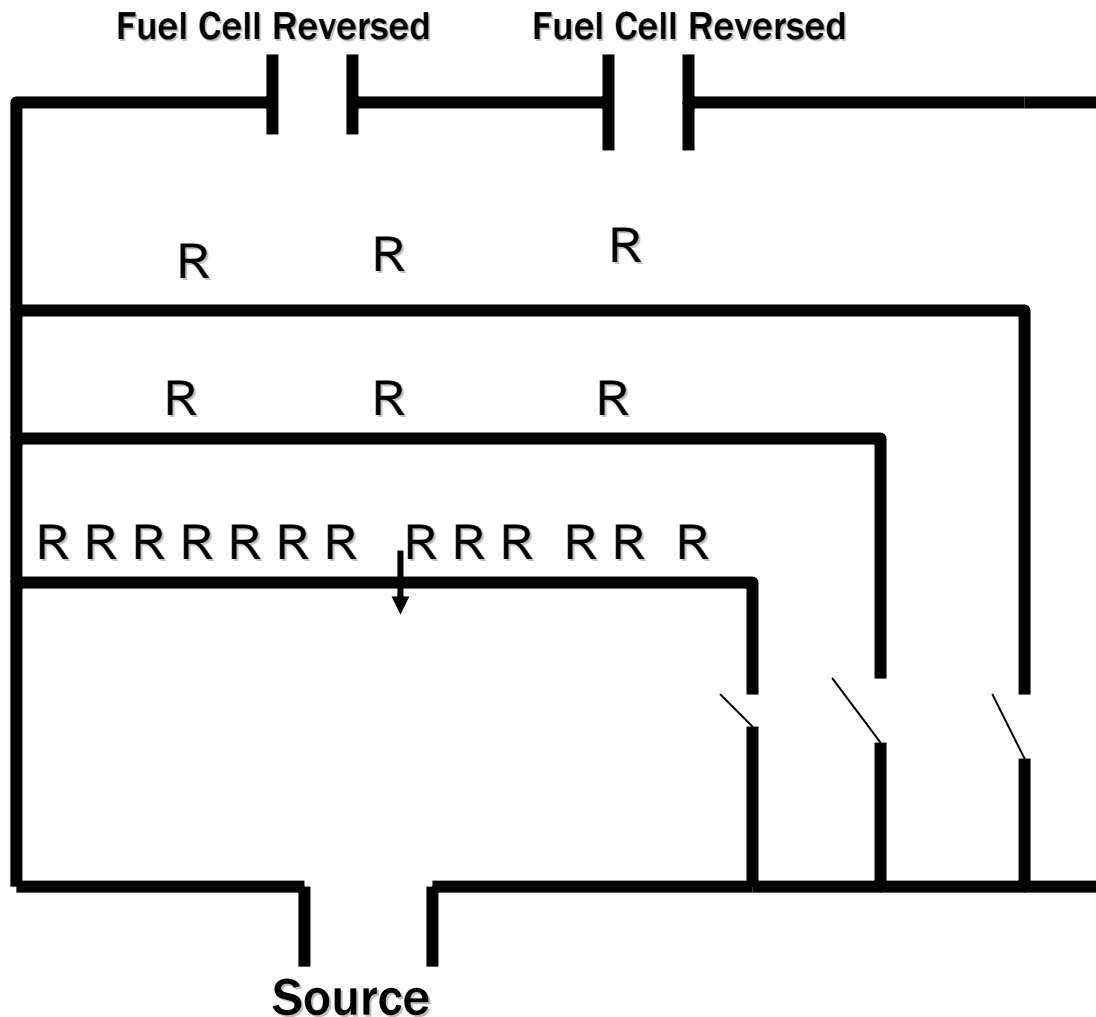

2 strings of 3 Motors

In series: 9-18V,
1.98 A (each motor)

Working rate: 10V,
1.1 A

Power per string: 33 W

13 lamps connected in
series, each one of 2.33 V
and 0.27 Amps.

Power: 8.2 Watts

**Total Model House
Power: 74.2 W**



HYDROGEN FLOW RATE FROM THE ELECTROLYZER

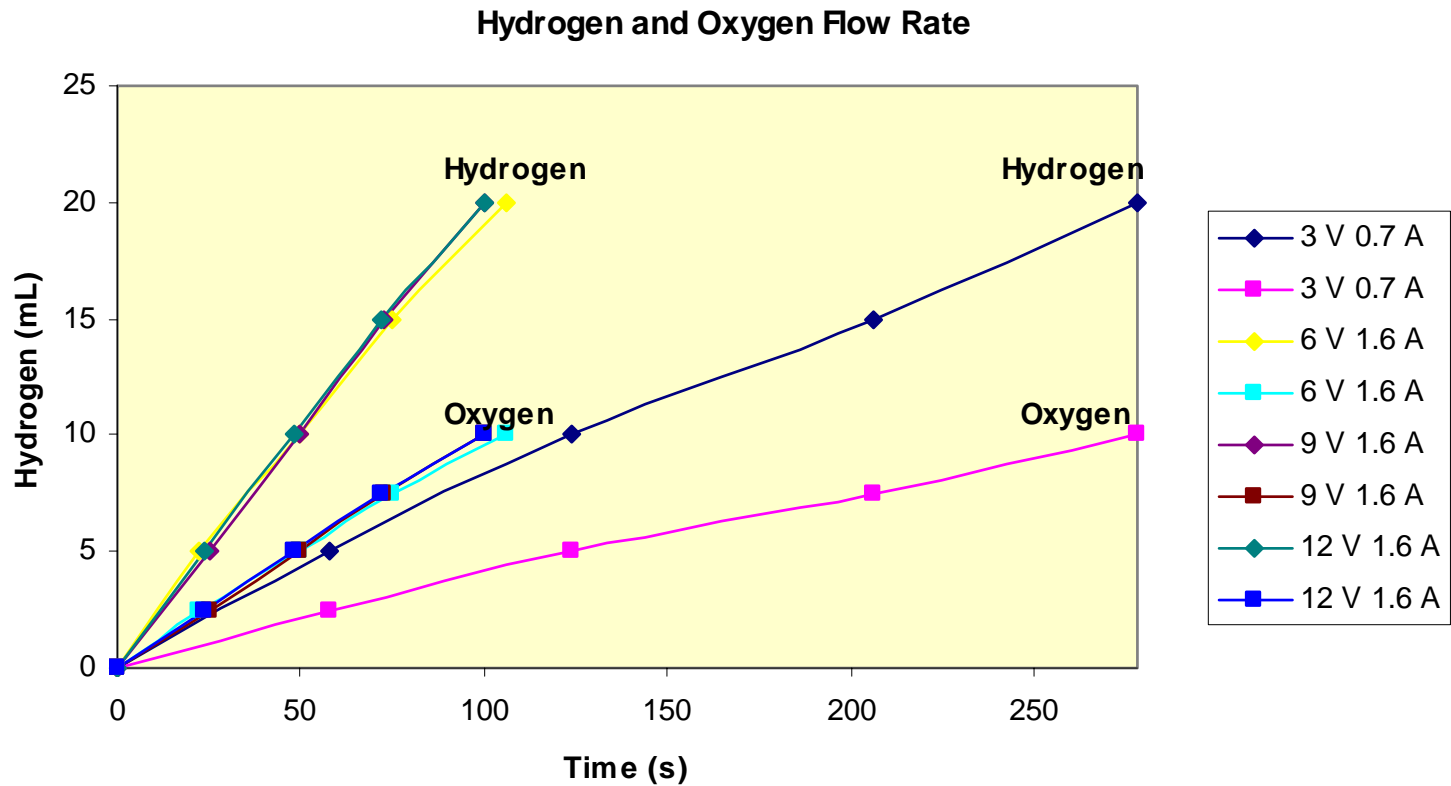

Fuel Cell Effective Area: 1.5 cm²

H₂

HYDROGEN PRODUCTION OF ENERGY FROM THE PV SYSTEM

Sample House

- Amount of available energy to produce Hydrogen
 - 80 Whr/day

- Electrolyze Production Rate
 - 9.6 Whr 0.0006 m³

- Hydrogen amount needed to run the house
 - @ 0.9 m³/hr 1000Watts
 - Therefore, we need 0.070 m³/day

- Maximum amount we can produce
 - 0.010 m³/day

Real House

- Amount of available energy to produce Hydrogen
 - 24 KWhr/day

- Electrolyze Production Rate
 - 5Kwhr 1 m³

- Hydrogen amount needed to run the house
 - @ 0.9 m³/hr 1000Watts
 - Therefore, we need 21.09 m³/day

- Maximum amount we can produce
 - 4.8 m³/day



CONCLUSIONS

- ❑ If the photovoltaic arrangement in a house is design to cover 100% of the energy requirements, then the amount of solar radiation collected by the solar cells will be sufficient to produce the total energy demanded by the house.
- ❑ The sample house and the real scale house, both have showed that the amount of hydrogen in a combined cycle of 9kW PV system and reversible fuel cell electrolysis, is not enough to cover the total energy demand for an average house. The PV arrangement needed to run the house 24 hrs is 34.3 kW.



H₂



FUTURE WORK

- ❑ Optimize the efficiency in the solar cells by using different materials such as Silicon Carbide.
- ❑ Optimize fuel cell efficiency. In this experiment we have worked with about 50 % efficiency.
- ❑ The amount of hydrogen that we are able to produce in a reversible process of a fuel cell is too low. Therefore, electrolysis has to be optimized as well.
- ❑ Study the efficiency vs. time of this type of system.



ACKNOWLEDGEMENTS

- ❑ United States Department of Energy
- ❑ Brookhaven National Laboratory
- ❑ Noel Blackburn
- ❑ Prof. Devinder Mahajan
- ❑ SUNY Farmingdale
- ❑ Prof. Hazem Tawfik
- ❑ Prof. Kamel Khatib